

heinrich

AIR VISES ... single-acting cylinders

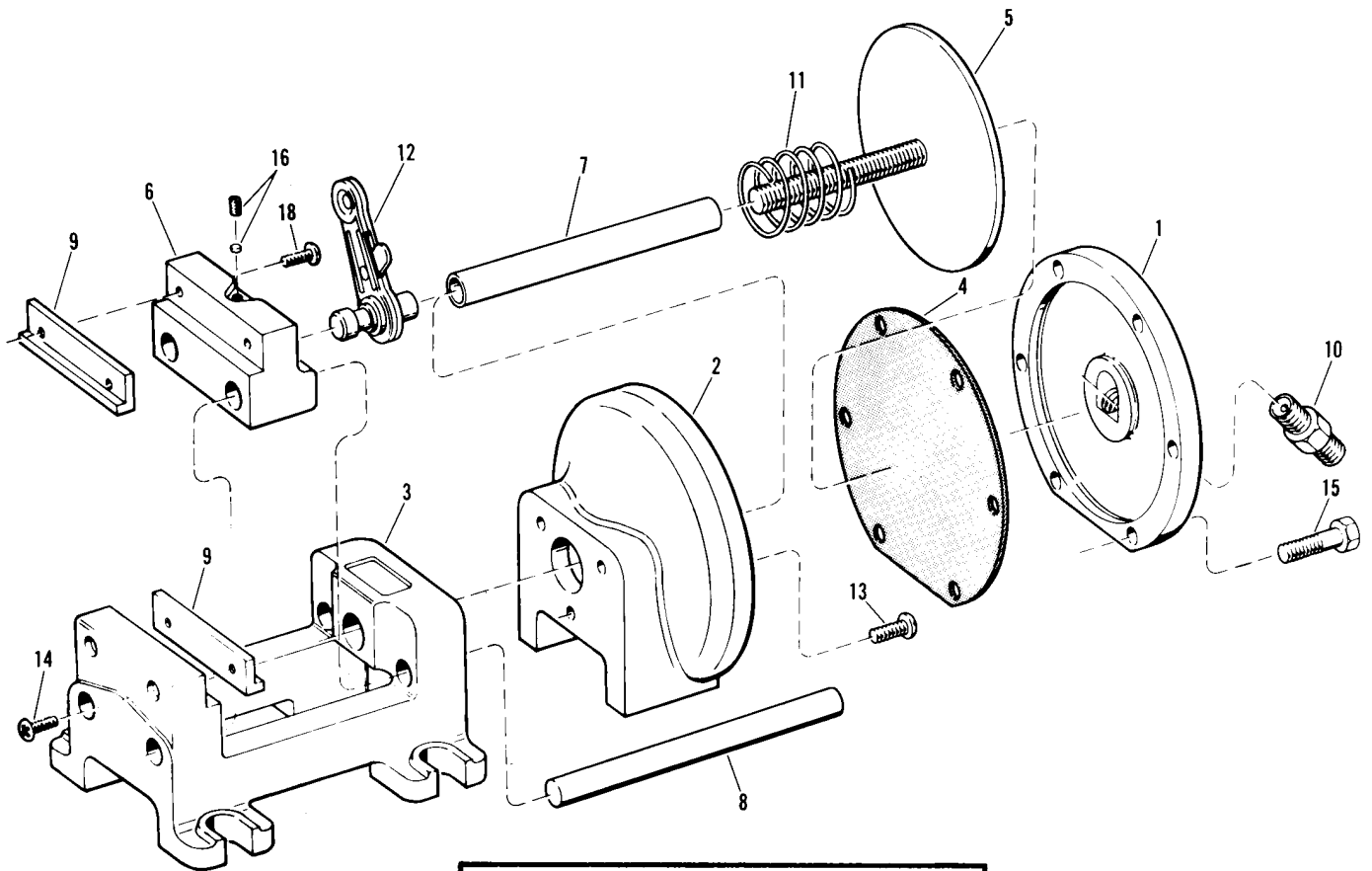

CAUTION: For Maximum operator protection when the setup might cause the employee to place his hands or fingers within the point of operation, we suggest a two-hand control device, available through your air accessories distributor.

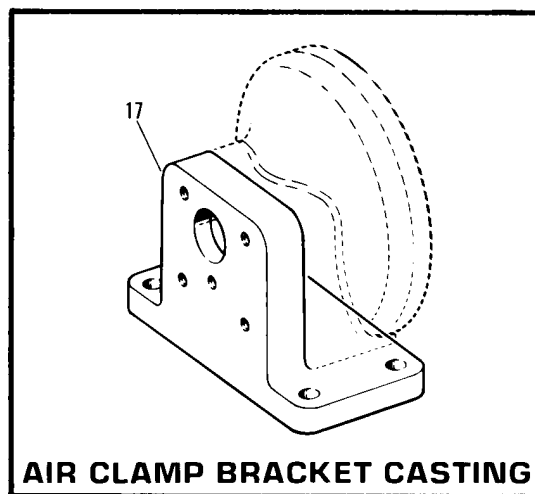

AIR CLAMP BRACKET CASTING



Index No.	Part Name	MODEL NUMBER			
		33 Vise 55-3 Clamp		44-Vise 55-4 Clamp	
		Part No.	Price	Part No.	Price
1	Cylinder Head Casting	33-1	\$41.02	33-1	\$41.02
2	Cylinder Body Casting	33-2	54.69	33-2	54.69
3	Body Casting (Note 1)	33-3	--	44-3	--
4	Diaphragm	33-4	18.87	33-4	18.87
5	Piston Head, with Adjusting Screw	33-5	34.46	44-5	34.46
6	Jaw Casting	33-7	51.27	44-7	51.27
7	Center Bar Nut	33-13	27.89	44-13	34.46
8	Guide Bars (2 required)	314	11.96	44-14	15.38
9	Jaw inserts, regular (set of 2)	319	18.05	44-19	21.33
9	Jaw Inserts, hardened (set of 2)	319H	24.61	44-19H	31.17
10	Adapter	33-16	3.61	33-16	3.61
11	Cylinder Spring	33-24	24.61	33-24	24.61
12	Ratchet Assembly	33-25	27.89	33-25	27.89
13	5/16-18 x 3/4 Screw (3 req.)	33-8	0.98	33-8	0.98
14	1/4-20 x 3/4 Screw (2 req.)	30-3/4	1.89	30-3/4	1.89
15	5/16-18 x 7/8 Screw (6 req.)	33-17	1.07	33-17	1.07
16	1/4-28 x 5/8 Screw with locking slug	33-18	2.95	33-18	2.95
17	Bracket Casting	55-1	145.28	55-1	145.28
18	1/4-20 x 1/2 Screw (2 req.)	30-1/2	0.98	--	0.98
18	1/4-20 x 5/8 Screw (2 req.)	--	--	30-5/8	1.89

Note 1. Price not shown, as replacement body castings are not available.

WHEN ORDERING PARTS, INDICATE PART NUMBER, MODEL NUMBER AND PRICE.

OPERATION:

Connect one of the two identical hoses to the adapter on the air cylinder and to the side fitting on the three-way valve, marked "OUT." Connect the other hose to the end adapter on the valve marked "IN" and to the air supply line.

Heinrich air units can be used safely on air supply lines with pressures up to 120 psi.

To adjust jaw opening, **first loosen the locking set screw on the top of the movable jaw**, allowing just a slight amount of tension on the ratchet plug; then the ratchet will move freely to adjust the jaw to the desired opening. For maximum speed of operation and life of diaphragm, a stroke of no more than 1/16" is recommended. After setting Heinrich air vises, the **set screw on top of the movable jaw should be locked securely**.

The range of holding power can be controlled by installing an Air Regulator, between the air supply line and the three-way valve.

While all operating parts are protected from oils, coolants, chips, etc., the air cylinder and controls could be damaged by foreign matter in the air line. This can be prevented by using an Air Filter, between the air supply and the air regulator and/or control valve. A Combination Filter-Regulator may be used in place of the separate filter and regulator.

MAINTENANCE:

An occasional oiling of the guide and center bars is recommended. Disassemble the air cylinder as follows: First, shut off the air supply; clamp the movable jaw tightly to the stationary jaw with a C-Clamp (and do not remove until the cylinder head (1) is securely replaced); then remove the six screws and cylinder head (1). Care should be taken in removal of the piston head with adjusting screw (5) because of the tension on the cylinder spring (11).

To remove ratchet (12) from center bar nut (7), remove piston head with adjusting screw (5), insert 3/8" dia. x 2" long pin in center bar nut (7). Thread piston (5) into center bar nut (7) until ratchet is forced off from its press fit in the center bar nut. To remove ratchet (12) from jaw (6), remove set screw (16), and tap or drill out slug (16).

Clean and check each part for wear or damage. Replacement parts are available for immediate shipment from factory stock, or you may order through your local Heinrich distributor.

After replacing diaphragm and cylinder head, screws should be evenly and firmly tightened.